

PHILCO Models 39-70, 39-75, 39-80, Code 121-122

Specifications

TYPE OF CIRCUIT: Models 39-70, 39-75 and 39-80 are four tube battery operated superheterodyne receivers covering standard broadcast and state police stations. The receivers employ the new Philco Farm Radio Tubes, which require exceptionally low current for operation, Automatic Volume Control, and a Philco Speaker designed especially for battery radio. In general these models are similar but differ in their tuning mechanisms, speakers and cabinets.

Model 39-70 is manually tuned and is assembled in cabinet types "F" (floor model) and "B" (table model).

Model 39-75, codes 121 and 122 is equipped with automatic push-button and manual tuning. The automatic tuning mechanism contains six push-buttons for selecting any of six stations in the standard broadcast band. The procedure for adjusting and operating the push-buttons will be found in the instructions supplied with each set.

Code 122 of this model is assembled in cabinet type "F" (floor model): Code 121 in cabinet type "T" (table model).

Model 39-80 is manually tuned and is assembled in cabinet type "B" (table model) and cabinet type "XF" (floor model).

In addition to the new Philco speaker in Model 39-80 a sound chamber is also built into the cabinet. This sound chamber reinforces the sound produced by the speaker and results in greater clarity of tone and intensity of sound output. Bass compensation is also included in the volume control circuit.

TUNING RANGE: 530 to 1720 K. C.

INTERMEDIATE FREQUENCY: 470 K. C.

PHILCO TUBES: One 1A7G, First Detector and Oscillator; one 1N5G, I. F. Amplifier; one 1H5G, Second Detector; First Audio and Automatic Volume Control, and one 1C5G (1A5G Model 39-80) Pentode Output.

BATTERIES REQUIRED: One (1) Philco "A" Pack, Part No. 41-8014; one (1) Philco "B" Pack, Part No. 41-8015.

INSTALLING BATTERIES: The batteries are arranged in the cabinet in such a manner that they form part of the sound chamber air column.

Instructions for setting up and operating the automatic push-button tuning will be found on page 3.

Alignment of Compensators

EQUIPMENT REQUIRED:

(1) Signal Generator: Philco Model 077 Signal Generator which has a fundamental frequency range from 115 to 36,000 K. C. is the correct instrument for this purpose.

(2) Output Meter, Philco Model 027 Circuit Tester, incorporates a sensitive output meter and is recommended.

(3) Philco Fiber Handle Screw Driver, Part No. 27-7059, and Fiber Wrench, Part No. 3164.

It is very essential, therefore, that the following instructions be carefully observed when installing the batteries. Remove the back from the cabinet after removing the wood screws which hold it in place. Place the small "A" Pack in the left side (looking at the cabinet from the rear) of the cabinet, three inches in from the rear with the slanting portion facing the front of the cabinet. Place the long "B" Pack along the rear of the cabinet with the socket for the battery cable plug at the top towards the front.

Observe the arrangement of pins on the plugs of the battery cable and the corresponding holes in the sockets of the batteries, so you will be sure to insert them correctly. Insert plug with two prongs into the small "A" Pack and the plug with three prongs into the large "B" Pack.

Replace the back on the cabinet with the wood screws, making sure all of them are screwed in tight.

BATTERY DRAIN:

Models 39-70 and 39-75... "A"—(250 M. A.) "B"—(8½ M. A.)
Model 39-80... "A"—(200 M. A.) "B"—(6½ M. A.)

AERIAL AND GROUND: In order to obtain the highest amount of sensitivity from these receivers the Philco Farm Radio Aerial, Part No. 40-6383, should be used. This aerial is accurately designed to match the tuned antenna circuit in the receiver so that maximum performance will be obtained.

A good ground connection to the nearest water pipe or any other good ground source is also required.

CABINET DIMENSIONS:

Model	Height	Width	Depth
39-70B	13 7/8"	11 7/8"	6 1/4"
39-70F	37 1/8"	23"	9 5/8"
39-75T	8 5/8"	13"	6 3/4"
39-75F	37 1/8"	23"	9 5/8"
39-80B	17 1/2"	17 1/2"	9 1/2"
39-80XF	39 3/4"	24 1/4"	12 1/2"

OUTPUT METER: The Philco 027 Output Meter is connected to the plate and screen terminals of the type 1C5G tube in Models 39-70 and 39-75 (1A5G Model 39-80) and adjusted for the 0 to 30 V. A. C. scale. After connecting the output meter, adjust the compensators in the order as shown in the tabulation below. Locations of the compensators are shown on page 2. If the output meter pointer goes off scale when adjusting the compensators, reduce the strength of the signal from the generator.

PROCEDURE FOR MODELS 39-70 AND 39-75

Operations in Order	SIGNAL GENERATOR			RECEIVER			
	Output Connections to Receiver	Dummy Antenna Note A	Dial Setting	Dial Setting	Control Setting	Adjust Compensators	Special Instructions
1	1A7G Grid	.1 mfd.	470 K. C.	580 K. C.	Vol. Max.	12A, 11B, 11A	
2	Ant. (White)	225 mfd.	1550 K. C.	1550 K. C.	Vol. Max.	4B, 4A	Note B Note C

PROCEDURE FOR MODEL 39-80

Operations in Order	SIGNAL GENERATOR			RECEIVER			
	Output Connections to Receiver	Dummy Antenna Note A	Dial Setting	Dial Setting	Control Setting	Adjust Compensators	Special Instructions
1	1A7G Grid	.1 mfd.	470 K. C.	580 K. C.	Vol. Max.	13A, 12B, 12A	
2	Ant. (White)	225 mfd.	1550 K. C.	1550 K. C.	Vol. Max.	4B, 4A	Note B Note C

Alignment Notes

NOTE A—The "Dummy Antenna" consists of a condenser or resistor connected in series with the signal generator output lead (high side). Use the capacity or resistance as specified in each step of the above procedure.

NOTE B—**DIAL CALIBRATION:** In order to adjust the receiver correctly, the dial must be aligned to track properly with the tuning condenser.

Model 39-70 and 39-80—To adjust the dial proceed as follows: Turn the tuning condenser to maximum capacity (plates fully meshed). With the tuning condenser in this position, set the pointer horizontally across the dial.

Model 39-75—With the tuning condenser in the maximum capacity position (plates fully meshed), loosen the coupling screws connecting the push-button unit to the condenser. The pointer is then set on the extreme left edge of the index line (low frequency end of the scale) with the tuning condenser fully closed. The gang is then opened until the pointer is at the right edge of the index line. The push-button shaft is then turned counter-clockwise to its "stop." With the tuning condenser and push-button shaft in these positions tighten the coupling set screws.

NOTE C—The locations of the compensators in Models 39-70, 39-75 and 39-80 are shown in Figs. (1), (2) and (3) respectively.

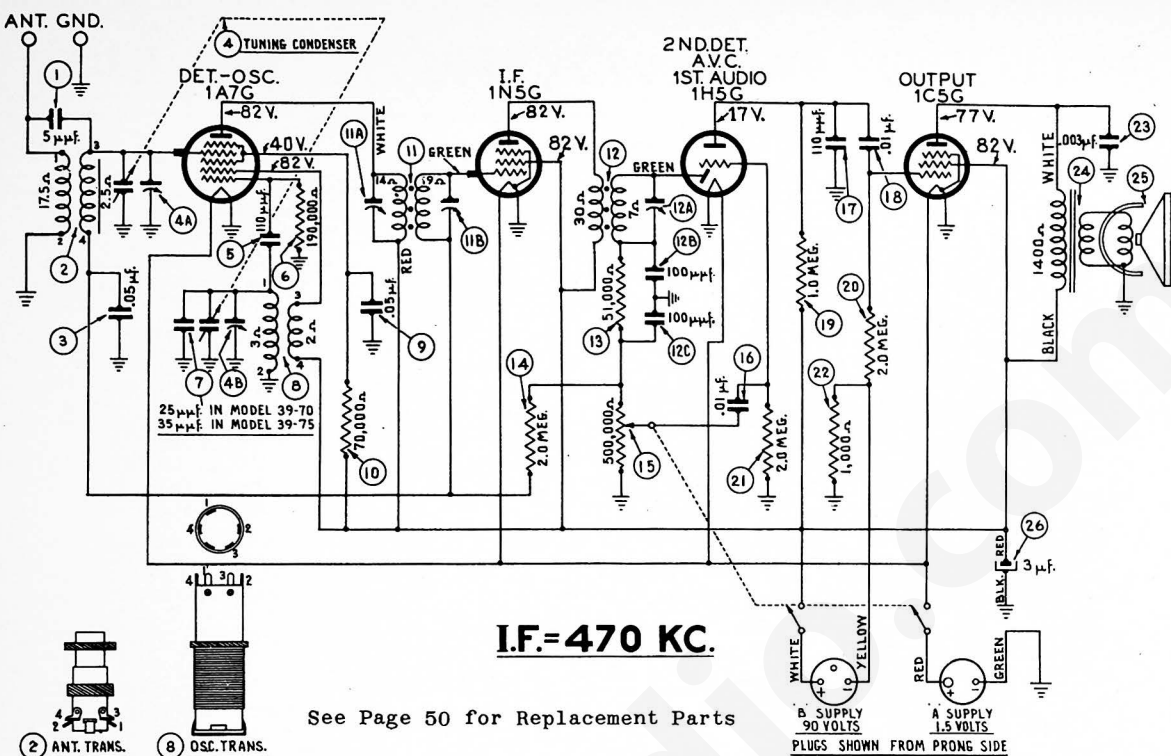

SCHEMATIC DIAGRAM MODEL 39-70 & 39-75

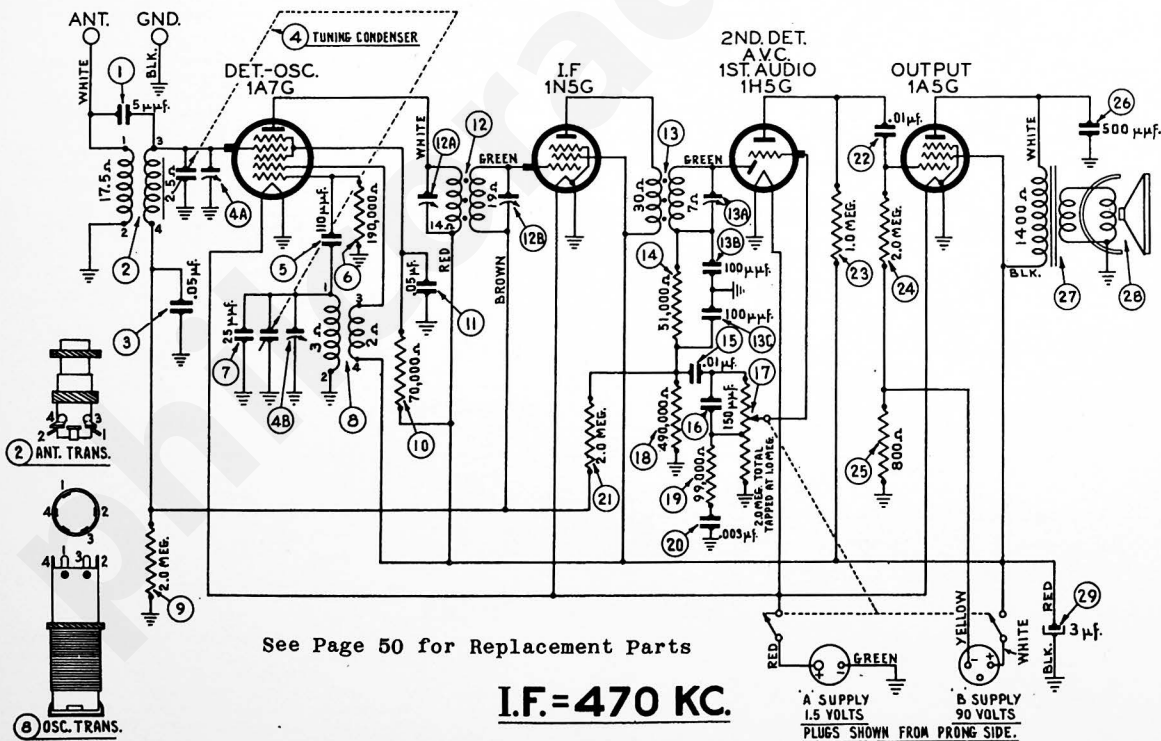

SCHEMATIC DIAGRAM MODEL 39-80

PHILCO Models 39-70, 39-75, Code 121-122

REPLACEMENT PARTS Models 39-70, Code 121, and 39-75, Codes 121-122

Schem. No.	Description	Part No.	Schem. No.	Description	Part No.
1	Condenser (5 mmf. mica) (Part of No. 2)	30-1097	14	Resistor (2.0 megohms, 1/2 watt)	33-520339
2	Antenna Transformer (Includes No. 1)	32-3080	15	Volume Control and On-Off Switch, 39-70	33-5290
3	Condenser (.05 mf. tubular)	30-4519		Volume Control and On-Off Switch, 39-75	33-5291
4	Tuning Condenser Assembly, 39-70	31-2100	16	Condenser (.01 mf. tubular)	30-4572
	Tuning Condenser Assembly, 39-75	31-2265	17	Condenser (110 mmf. mica)	30-1031
5	Condenser (110 mmf. mica)	30-1031	18	Condenser (.01 mf. tubular)	30-4572
6	Resistor (190,000 ohms, 1/2 watt)	33-419339	19	Resistor (1.0 megohm, 1/2 watt)	33-510339
7	Condenser (25 mmf. mica), 39-70	30-1067	20	Resistor (2.0 megohms, 1/2 watt)	33-520339
	Condenser (35 mmf. silver plated mica), 39-75	30-1113	21	Resistor (2.0 megohms, 1/2 watt)	33-520339
8	Oscillator Transformer, 39-70	32-3019	22	Resistor (1000 ohms, 1/2 watt)	33-210339
	Oscillator Transformer, 39-75	32-3083	23	Condenser (.003 mf. tubular)	30-4469
9	Condenser (.05 mf. tubular)	30-4444	24	Output Transformer	32-7995
10	Resistor (70,000 ohms, 1/2 watt)	33-370339	*25	Cone and Voice Coil Assemblies—	
11	1st I. F. Transformer Assembly, 39-70	32-2841	39-70 "B" Spkr. Pt. No. 36-1435	36-4090	
	1st I. F. Transformer Assembly, 39-75	32-3078	39-70 "F" Spkr. Pt. No. 36-1447	36-4092	
12	2nd I. F. Transformer Assembly	32-3081	39-75 "B" Spkr. Pt. No. 36-1442	36-4090	
		32-3081	39-75 "F" Spkr. Pt. No. 36-1447	36-4092	
13	Resistor (51,000 ohms, 1/2 watt)	33-351339	26	Electrolytic Condenser (3 mf.)	30-2346

MISCELLANEOUS PARTS

Model 39-70, Code 121

Bezel Window	27-5417
Cable (Battery)	41-3427
Dial	27-5416
Dial Drive Cord	31-2317
Dial Drive Spring	28-8751
Dial Pointer	28-5468
Knob	27-4332

On-Off Indicator Parts—

Hub and Lever	38-9658
Toggle Link and Brkt. Assy.	38-9700
Spring (Toggle Link and Brkt. Assy.)	28-8925
Snap Fastener	56-1156
Pulley (Tuning Condenser)	28-6662
Pulley Screw (Tuning Condenser)	W-1400
Shaft Assy. (Tuning)	31-2290
*Speaker ("B" Cabinet)	36-1435
*Speaker ("F" Cabinet)	36-1447

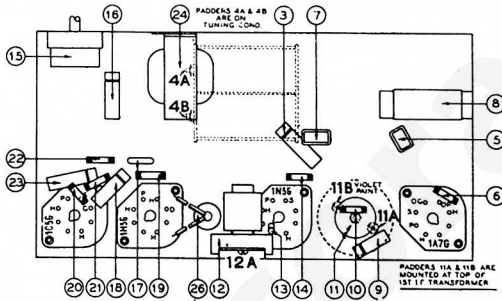

Fig. 1. Compensator and Part Locations
Model 39-70, Code 121
Underside of Chassis

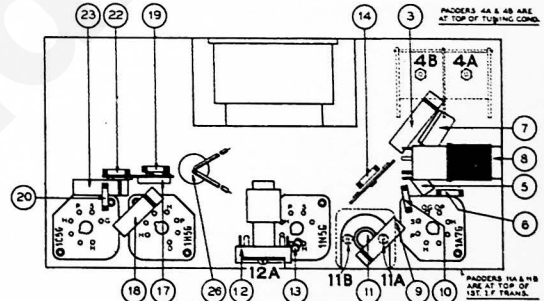

Fig. 2. Compensator and Part Locations
Model 39-75, Code 121-122
Underside of Chassis

Model 39-75, Code 121-122

Automatic Tuning Unit Complete	31-2282	Knob (Volume)	27-4753
Bezel (Dial)	40-6364	Knob (Tuning)	27-4750
Bezel Gasket (Dial)	27-9174	Knob Screw (Tuning)	28-6882
Bezel (Push-Button)	28-5929	Push-Button	27-4749
Bezel Gasket (Push-Button)	27-9218	Push-Button Spring	28-8918
Dial	27-5420	Sleeve—Short (Tuning Shaft, Code 121-122)	28-6887
Dial Pointer	28-5934	*Speaker (T Cabinet)	36-1442
Dial Drive Cord	31-2275	Socket (1A7G)	27-6099
Dial Drive Cord Spring	28-8919	Socket (6 prong)	27-6086
Dial Drive Drum (Tuning Condenser)	31-2281	Socket (7 prong)	27-6087

Model 39-75, Code 122

Extension Shaft (Volume)	38-9640	*Socket (Speaker)	27-6115
Extension Shaft (Tuning)	28-6928	*Speaker (Code 122)	36-1447
Extension Sleeve—Long (Tuning Shaft)	28-6935	Spring (Retaining Vol. Knob)	28-8915

PHILCO Model 39-80, Code 121

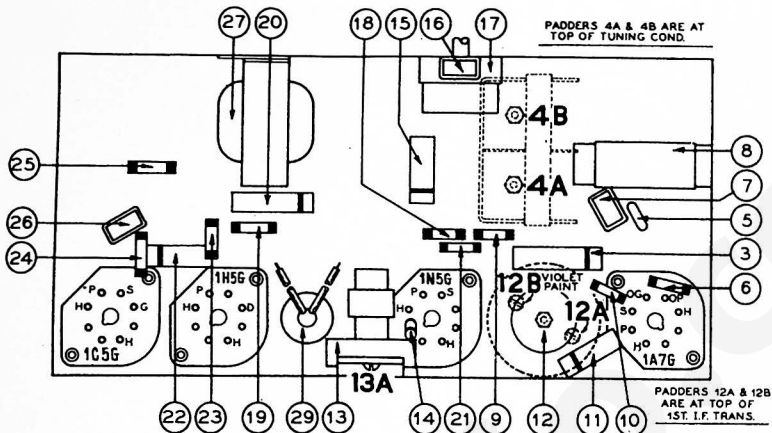

Fig. 3. Compensator and Part Locations
Model 39-80, Code 121
Underside of Chassis

Replacement Parts Model 39-80, Code 121

Schem. No.	Description	Part No.
1	Condenser (mica, 5 mmf.—Part of No. 2)	30-1097
2	Antenna Trans.	32-3080
3	Condenser (tubular, .05 mf.)	30-4519
4	Tuning Cond.	31-2300
5	Condenser (mica, (110 mmf.)	30-1031
6	Resistor (190,000 ohms, ½ watt)	33-419339
7	Condenser (mica, 25 mmfd.)	30-1067
8	Oscillator Trans.	32-3019
9	Resistor (2.0 meg., ½ watt)	33-520339
10	Resistor (70,000 ohms, ½ watt)	33-370339
11	Condenser (tubular, .05 mf.)	30-4444
12	1st I. F. Trans. Assy.	32-2841
13	2nd I. F. Trans. Assy.	32-3081
14	Resistor (51,000 ohms, ½ watt)	33-351339
15	Condenser (tubular, .01 mf.)	30-4572
16	Condenser (mica, 150 mmf.)	30-1033
17	Volume Control and On-Off Switch	33-5238
18	Resistor (490,000 ohms, ½ watt)	33-449339
19	Resistor (99,000 ohms, ½ watt)	33-399339
20	Condenser (tubular, .003 mf.)	30-4580
21	Resistor (2.0 meg., ½ watt)	33-520339
22	Condenser (tubular, .01 mf.)	30-4479
23	Resistor (1.0 meg., ½ watt)	33-510339
24	Resistor (2.0 meg., ½ watt)	33-520339
25	Resistor (800 ohms, ½ watt)	33-180339
26	Condenser (mica, 500 mmf.)	30-1114
27	Output Trans.	32-7984
28	Cone Assy. for Speaker 36-1410.	36-4093
	Cone Assy. for Speaker 36-1436.	36-4094
29	Electrolytic Condenser (3 mfd.)	30-2346
	Bezel Assy.	40-6374
	Bezel Screw	W-1834
	Brkt. (Mtg. Set in XF Cabinet)	56-1058
	Cable (Battery)	41-3437
	Dial	27-5413
	Dial Pointer	56-1091
	Dial Drive Cord	31-2318
	Dial Drive Cord Spring	28-8751
	Knob	27-4604
	On-Off Indicator Parts—	
	Hub and Lever	38-9658
	Toggle Link and Brkt. Assy.	38-9701
	Spring (Toggle Assy.)	28-8925
	Snap Fastener	56-1156
	Pulley (Tuning Condenser)	28-6662
	Pulley Screw (Tuning Condenser)	W-1400
	Shaft Assy. (Tuning)	31-2290
	Speaker (B Cabinet)	36-1410
	Speaker (XF Cabinet)	36-1436
	Socket (6 prong)	27-6086
	Socket (7 prong)	27-6087
	Socket (Speaker)	27-6115

PRODUCTION CHANGES 39-70, CODE 121

The electrolytic condenser (26) part number 30-2346 on some early receivers changed to part no. 30-2120. Either condenser can be used for replacement.